

# SECURISTYLE DEFENDER EGRESS

## friction hinges

Designed to allow easy window cleaning, Defender Egress has been specifically developed to meet “access in case of fire regulations” such as BS 5588.

It satisfies the increased safety requirements including emergency exit, now demanded by local authorities and other public bodies for side hung windows.

Providing proven weather-sealing and security of closure, the family of easy-fit Securistyle hinges offer clear cut features and benefits.

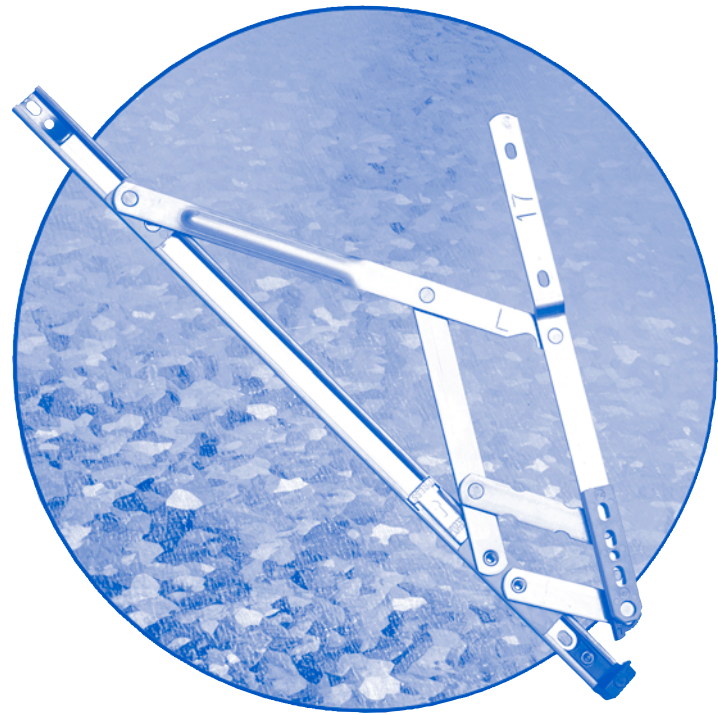

### Technical information

<b>Corrosion resistance:</b>	Meets the Requirements of BS EN 1670:2007
<b>Performance:</b>	Meets the requirements of BS6375-1:1989 Tested to 40,000 cycles of opening
<b>Operation:</b>	Meets the requirements of BS6375-2:1987 Complies with BS5588 part 1:1990

### Material specification

<b>Bars, Arms &amp; Rivets:</b>	Stainless Steel BS EN 10088-2:1995 Ferritic – 1.4016 (430 S17) Austenitic – 1.43.1 (304 S15)
<b>End Cap:</b>	Black Nylon
<b>Mouldings:</b>	Grey Nylon
<b>Friction Screw:</b>	Brass

### Product Options

Available in sizes 12” and 16”. Side hung.  
13mm, 16mm and 17mm stack height.  
See opposite for complete list of product codes.

Defender 16” Easy Clean Egress Hinge

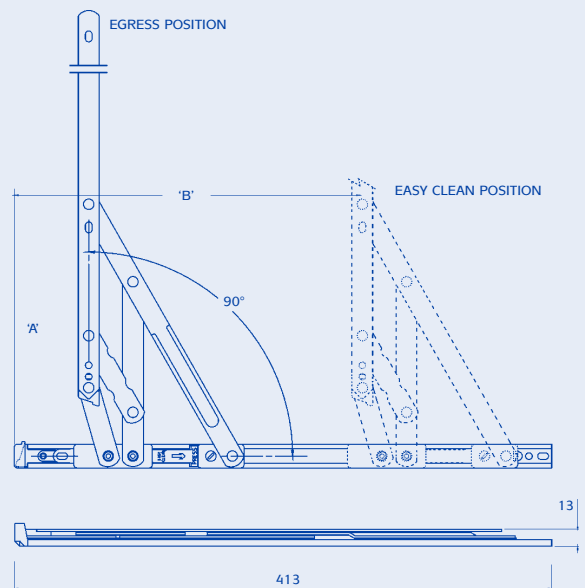

Sizes and capacities

Hinge Size (Side Hung) mm	Max Vent Weight kg	Max Vent Width mm	Min Vent Height mm	Dim 'A' mm	Dim 'B' mm	Opening Angle +/-2.5°
310 (12")	22	600	300	54	163	80°
412 (16")	24	700	400	57	268	90°



STACK



STACK



STACK



BS 5588



BS 6375



AUSTENITIC



FERRITIC



ASSESSMENT 1228



GUARANTEE

# SECURISTYLE DEFENDER EGRESS

## Part numbers

### EASYSIDE

Size		13mm	16mm	17mm
<b>Side hung</b>				
12"	310mm	WFDESL1280	WFDESF1280	WFDESH1280
16"	412mm	WFDESL1690	WFDESF1690	WFDESH1690

N.B. Austenitic available to special order

## Packing information

Size		No per pack	Weight
12"	310mm	25	11kg
16"	412mm	25	15kg